

**ADDENDUM NO. 1 – Portage Public Schools – 12<sup>th</sup> St. Elementary Monument Sign**

April 16<sup>th</sup>, 2026

The following items are changes, clarifications, corrections of errors, etc., with respect to the Contract Documents previously issued. This addendum shall be a part of the Contract Documents.

Items listed below may or may not affect the cost of the Contractor's Proposal. Changes in cost shall be incorporated in the Contractor's Proposal.

**ITEM No.1**

DRAWING AND SPECIFICATION CHANGES AS NOTED BY TOWER PINKSTER - ATTACHED

- See Tower Pinkster write up
- Specifications: None.
- Drawings: A101

**ITEM No.2**

PRE-BID CONTRACTOR MEETING – ATTACHED

## ADDENDUM NO. 1

<b>DATE OF ISSUANCE:</b>	<b>October 7, 2025</b>
<b>PROJECT:</b>	<b>12<sup>th</sup> Street Elementary School 6501 S. 12<sup>th</sup> Street Portage, MI 49024</b>
<b>OWNER:</b>	<b>Portage Public Schools</b>
<b>ARCHITECT'S PROJECT NO.:</b>	<b>24-117.000</b>
<b>ORIGINAL BID ISSUE DATE:</b>	<b>April 11, 2025</b>

---

### **SCOPE OF WORK**

This Addendum includes changes to, or clarifications of, the original Bidding Documents and any previously issued addenda, and shall be included in the Bid. All of these Addendum items form a part of the Contract Documents. The Bidder shall acknowledge receipt of this Addendum in the appropriate space provided on the Bid Form. Failure to do so may result in disqualification of the Bid.

### **DOCUMENTS INCLUDED IN THIS ADDENDUM**

This Addendum includes **two [2]** pages of text and the following documents:

- Bidding Documents: **None**
- Contract Conditions: **None**
- Specification Sections: **None**
- Drawings: **A101**

### **CHANGES TO PREVIOUSLY ISSUED ADDENDA**

None.

### **CHANGES TO BIDDING REQUIREMENTS**

None.

### **CHANGES TO CONTRACT CONDITIONS**

None.

### **CHANGES TO SPECIFICATIONS**

None.

## **CHANGES TO DRAWINGS**

### **ADD-1 Item No. D-1 - Monument Sign Clarifications**

Refer to Sheet(s): A101

Provide clarification on brick color and location. Provide aluminum color clarifications on Sign Box, Disk, and Letters. Revise letter sizing and justification.

**END OF ADDENDUM**

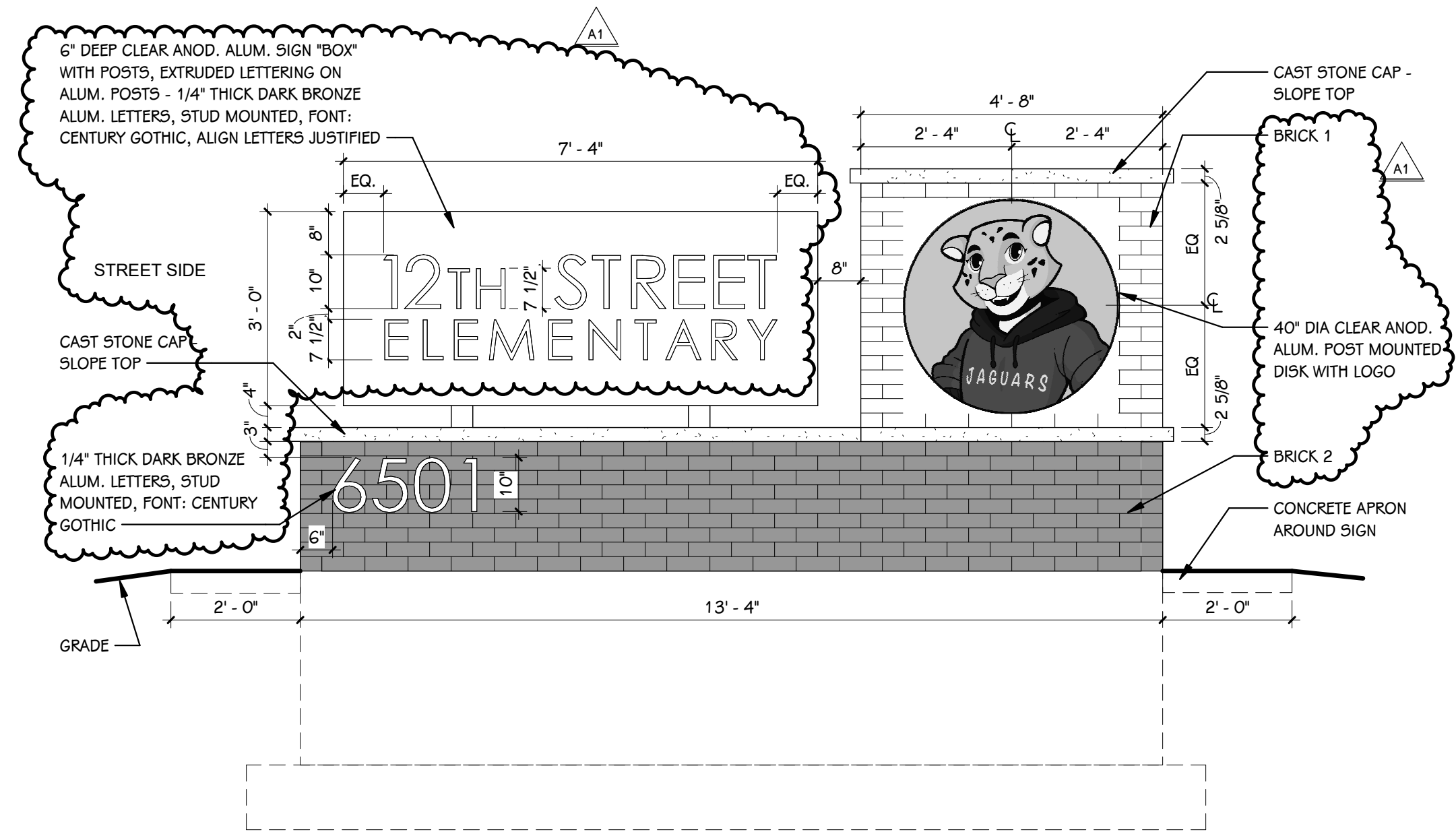

**A FRONT/BACK SIGN ELEVATION**  
1/2" = 1'-0"

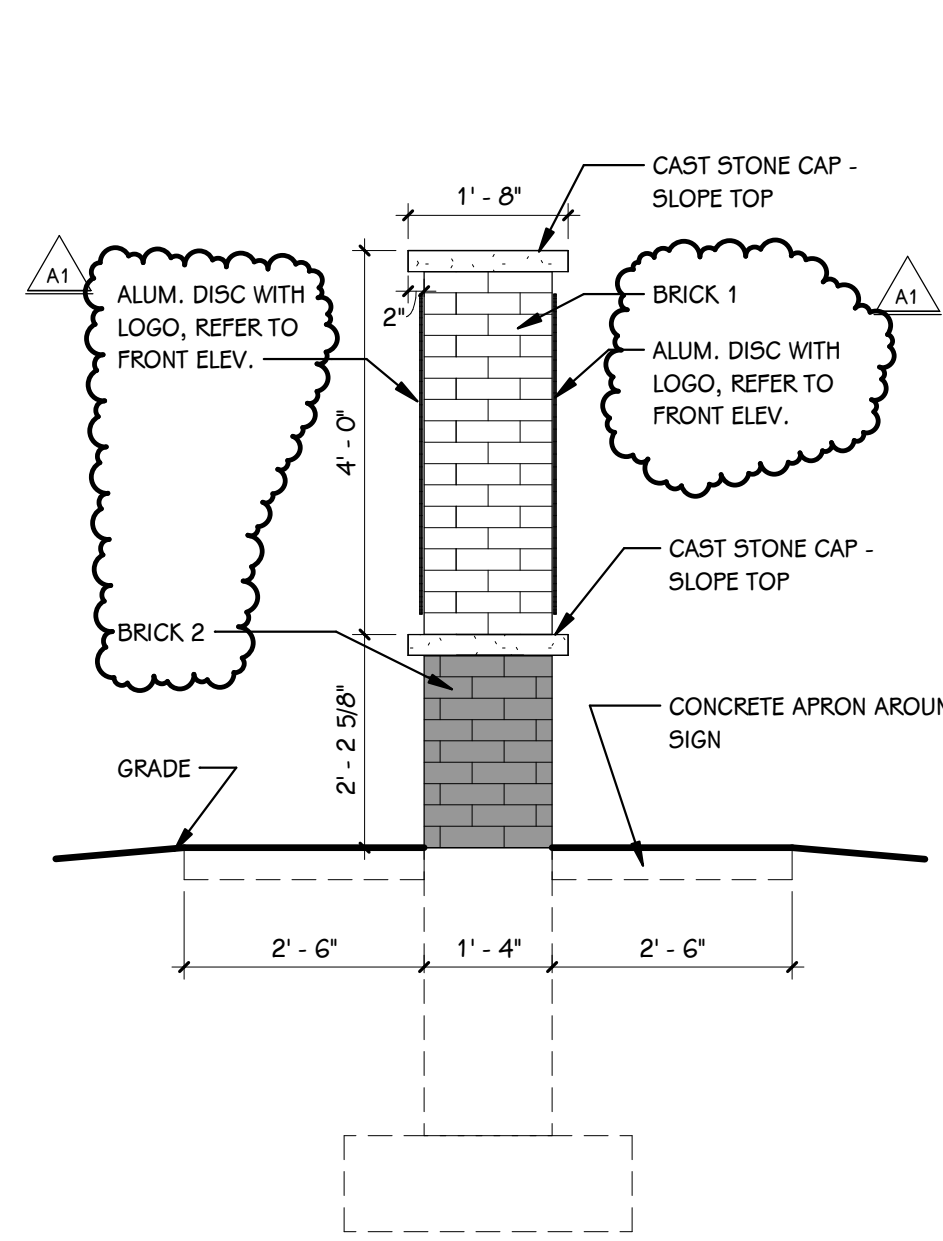

**B SIDE ELEVATION**  
1/2" = 1'-0"

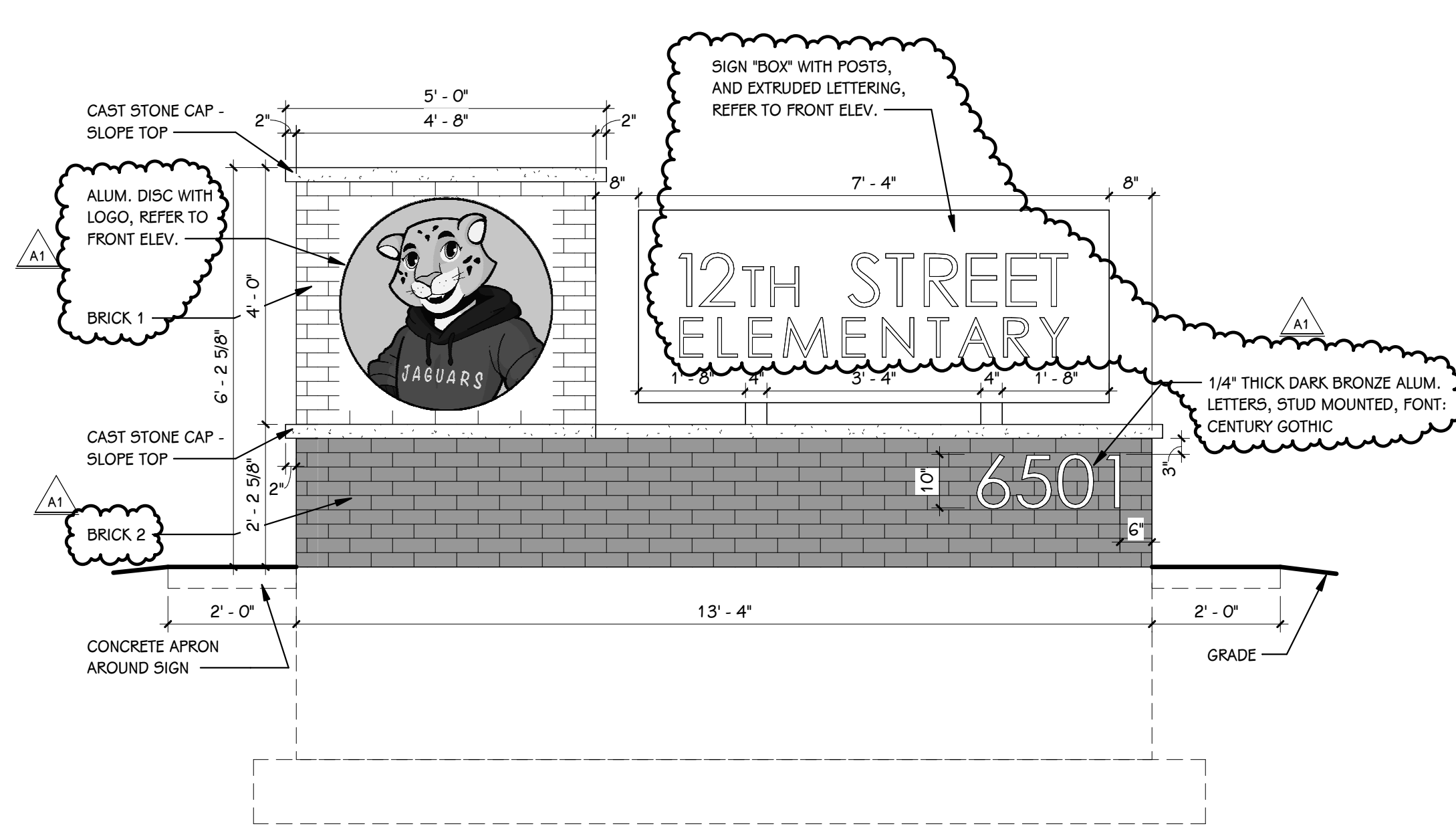

**C FRONT/BACK SIGN ELEVATION**  
1/2" = 1'-0"

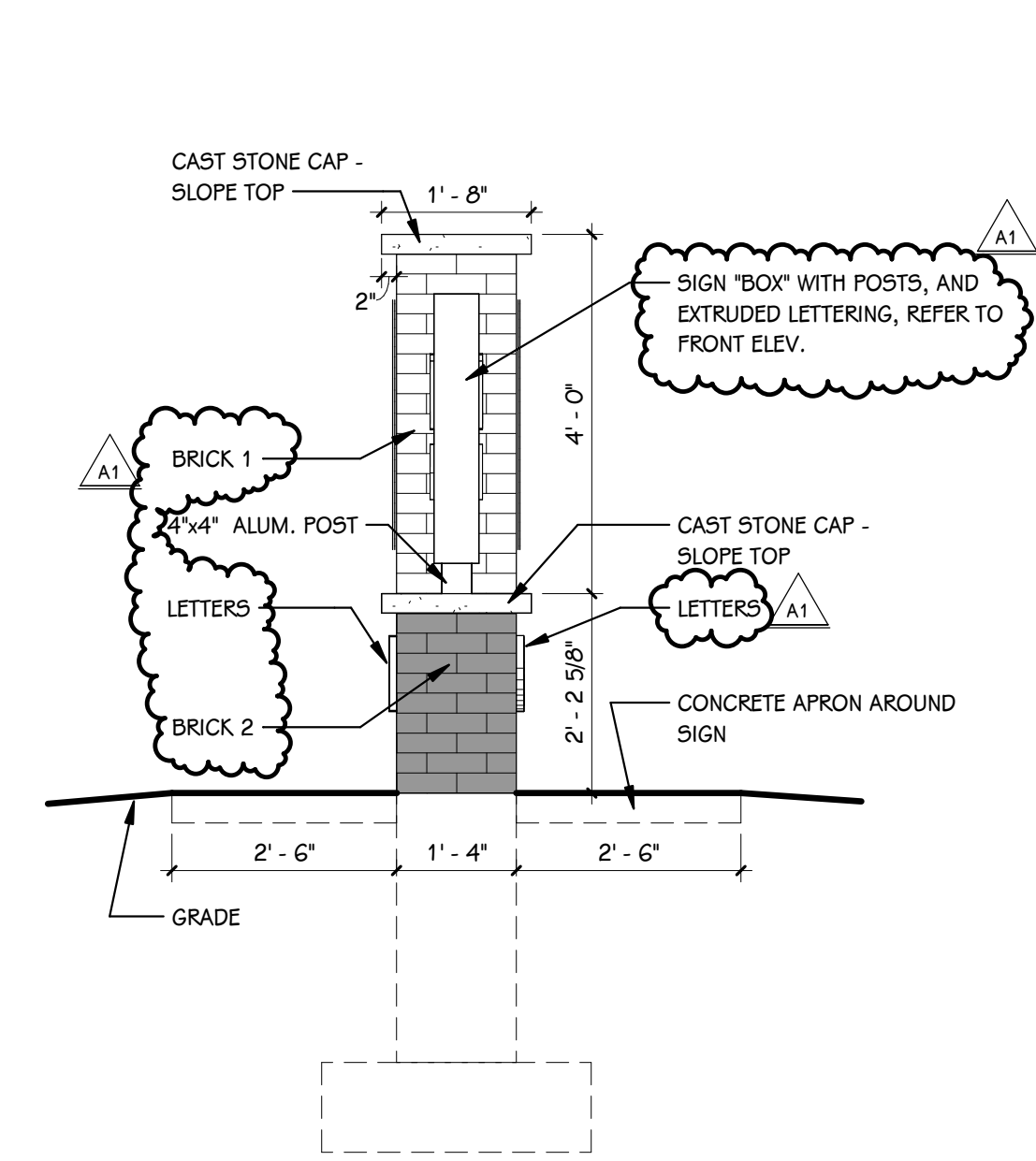

**D STREET SIDE ELEVATION**  
1/2" = 1'-0"

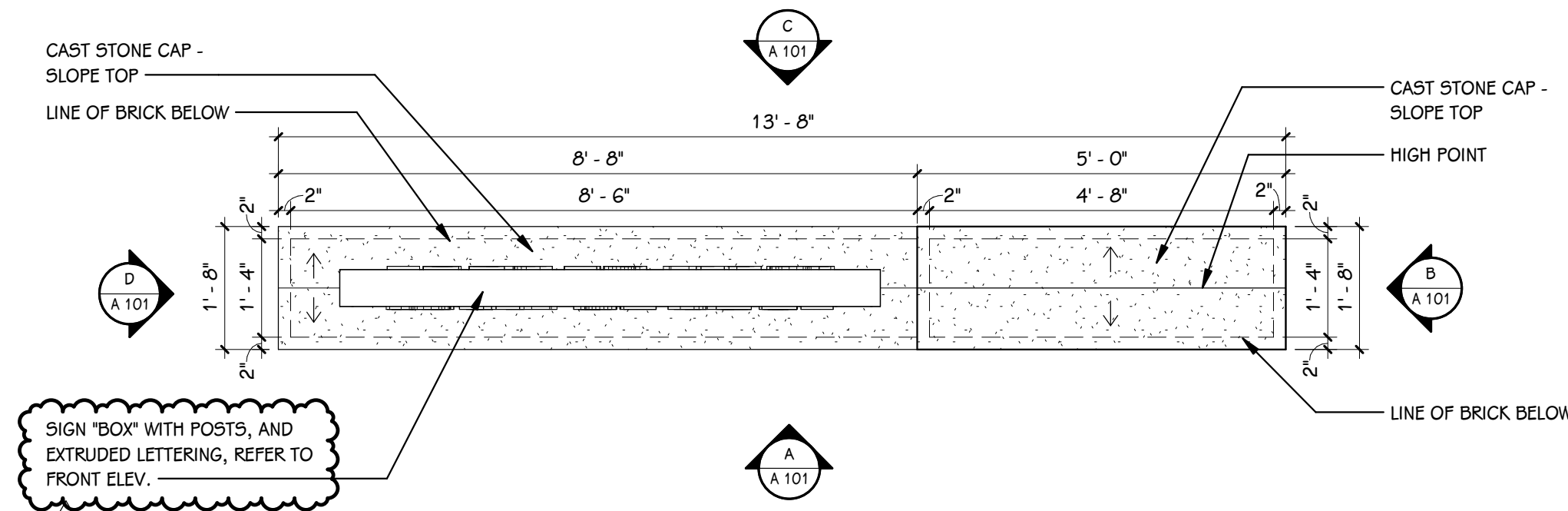

**1 SIGN PLAN - TOP OF SIGN**  
1/2" = 1'-0"

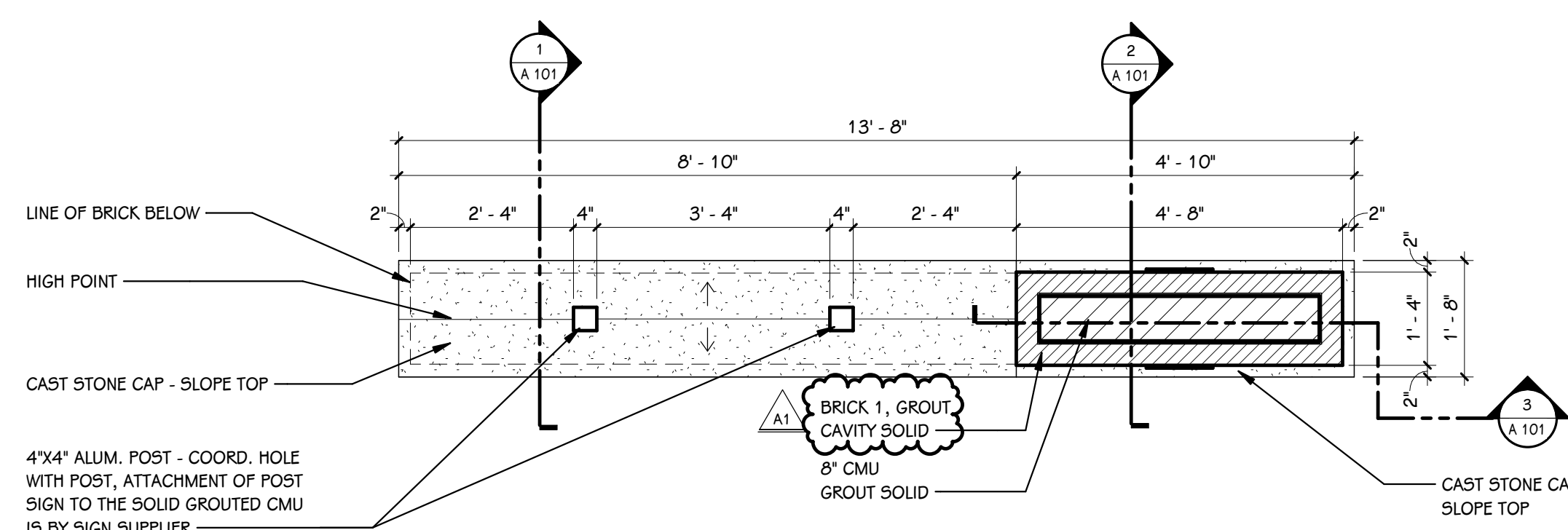

**2 SIGN PLAN**  
1/2" = 1'-0"  
NOTE: PLAN CUT AT 30" ABOVE GRADE

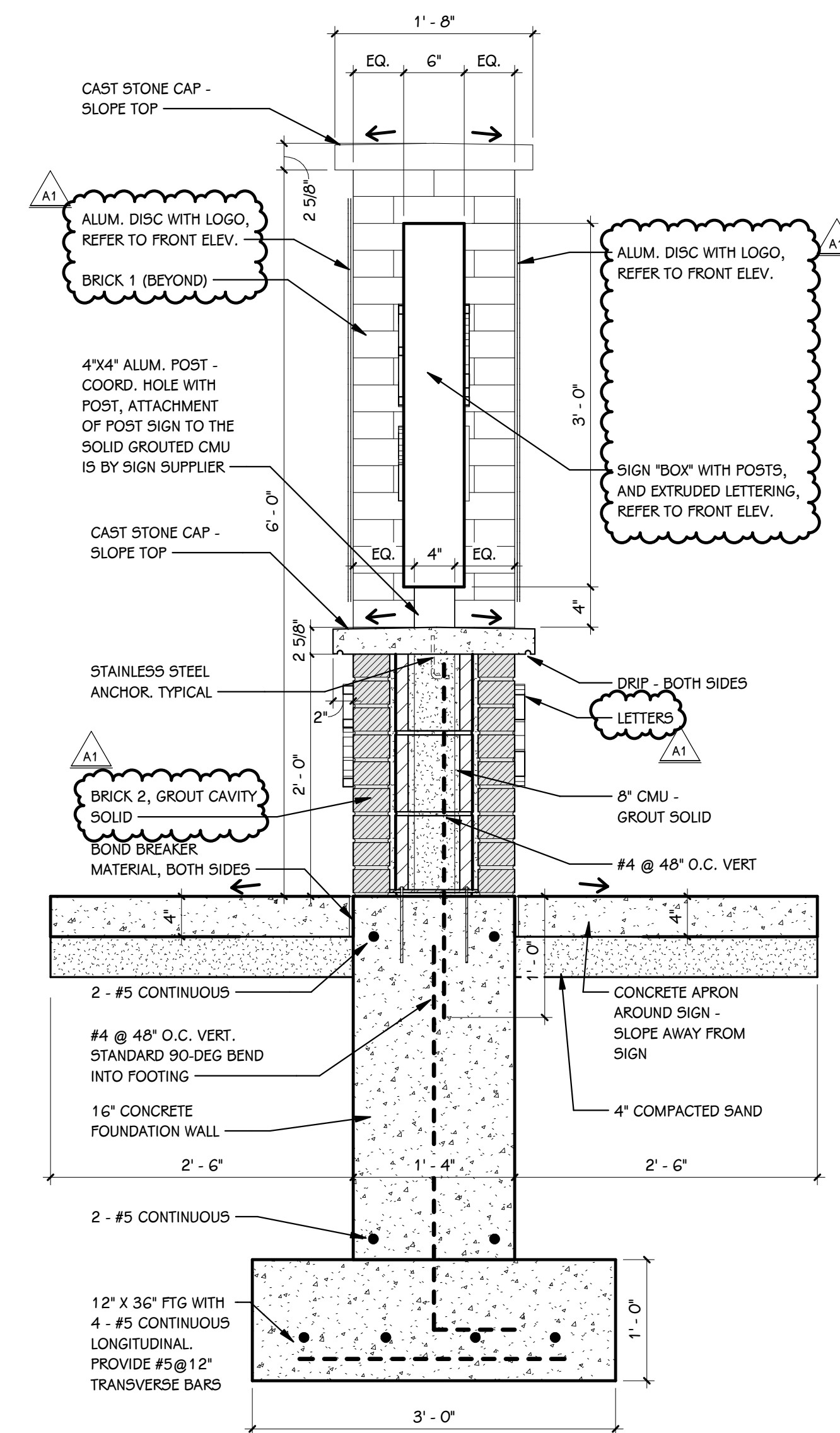

**1 SIGN SECTION**  
1" = 1'-0"

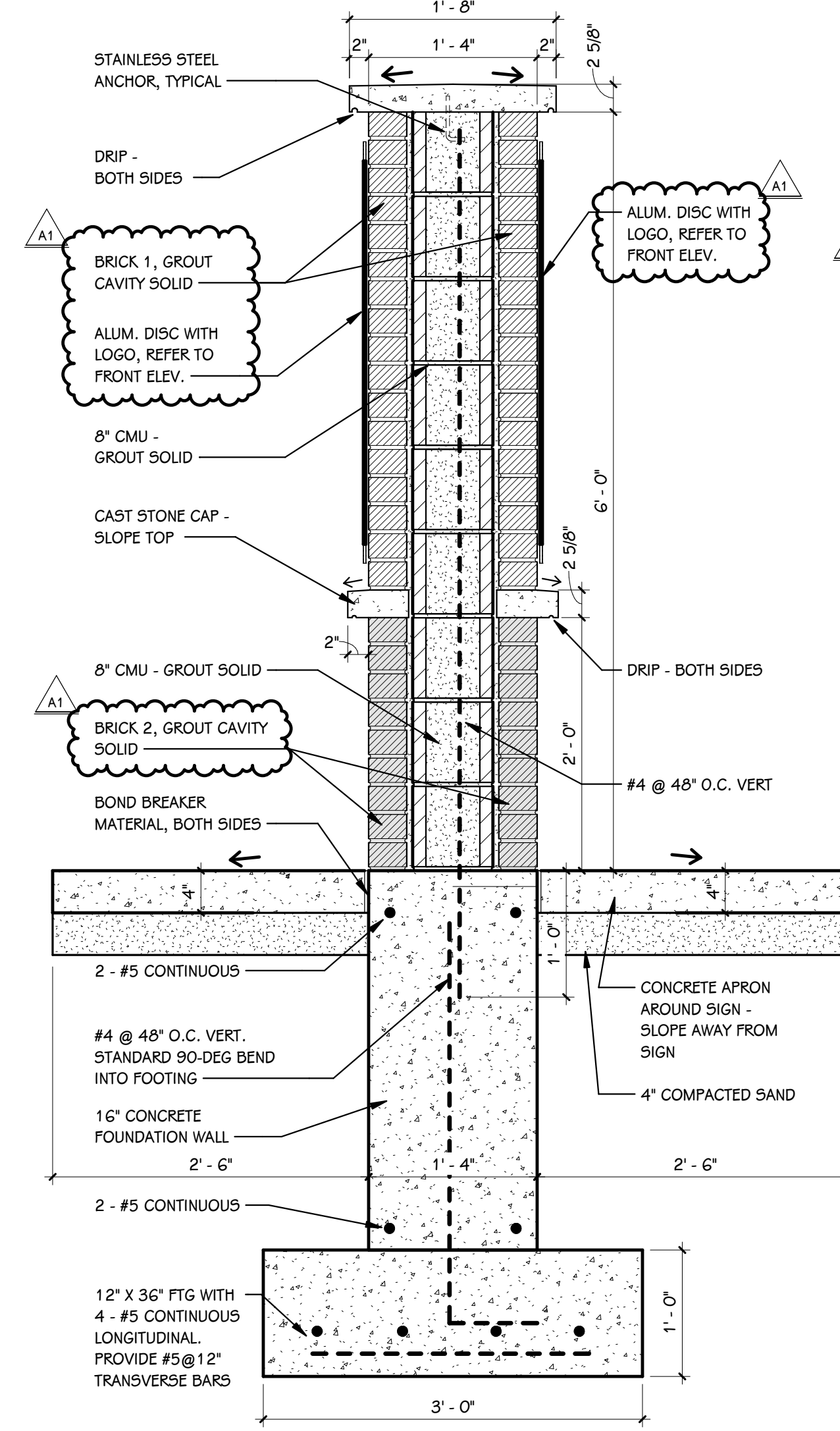

**2 SIGN SECTION**  
1" = 1'-0"

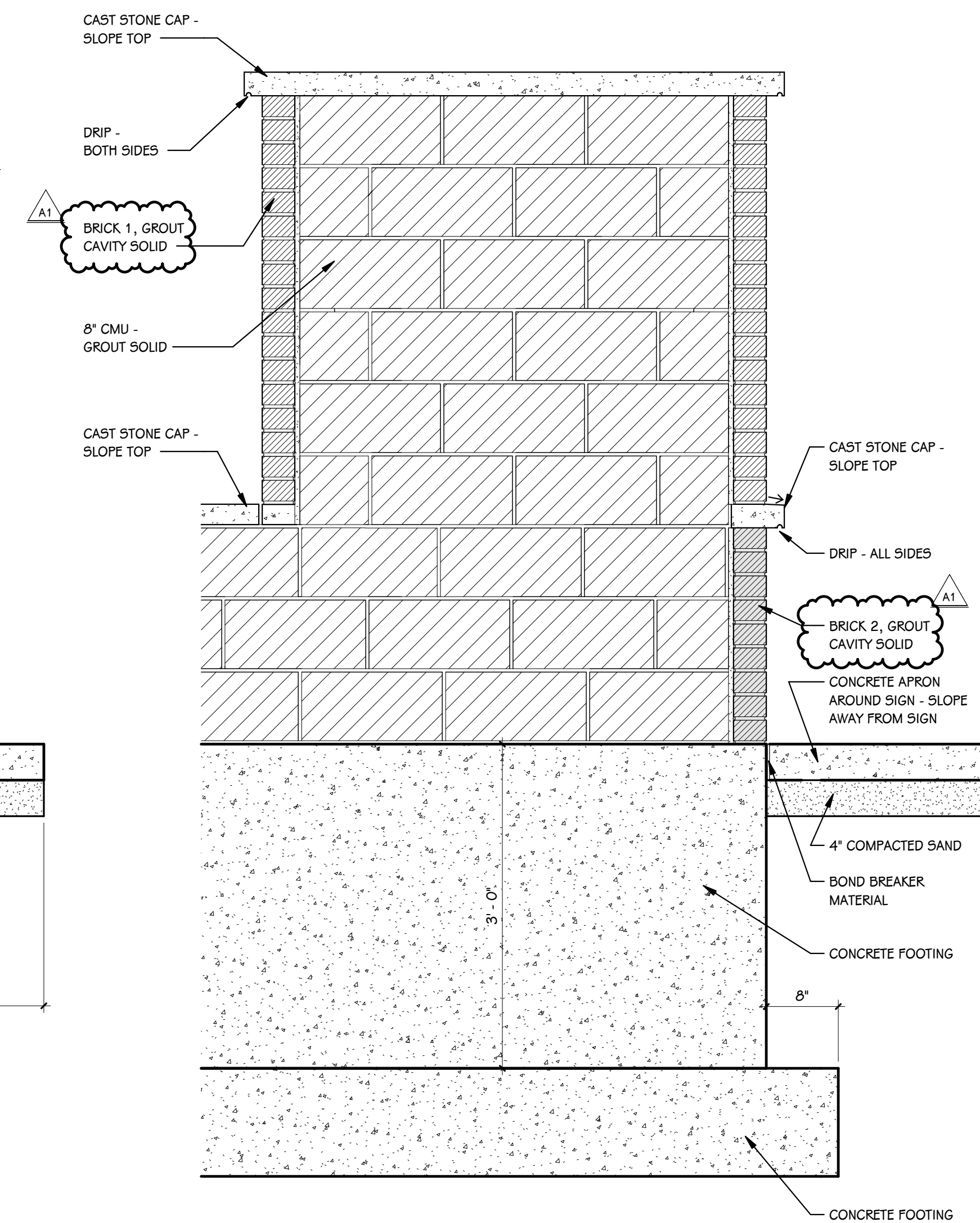

**3 SIGN SECTION**  
1" = 1'-0"

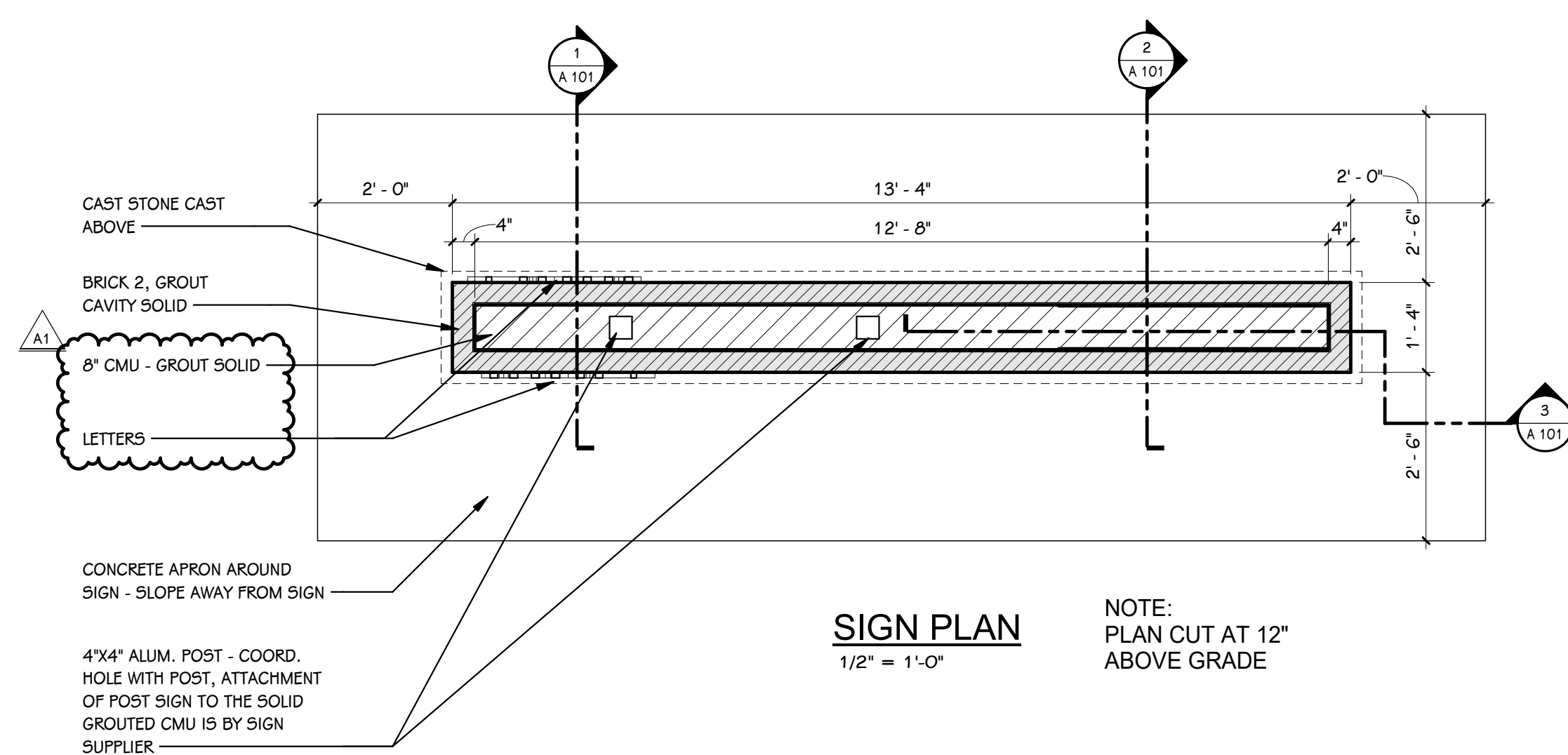

**3 SIGN PLAN**  
1/2" = 1'-0"  
NOTE: PLAN CUT AT 12" ABOVE GRADE

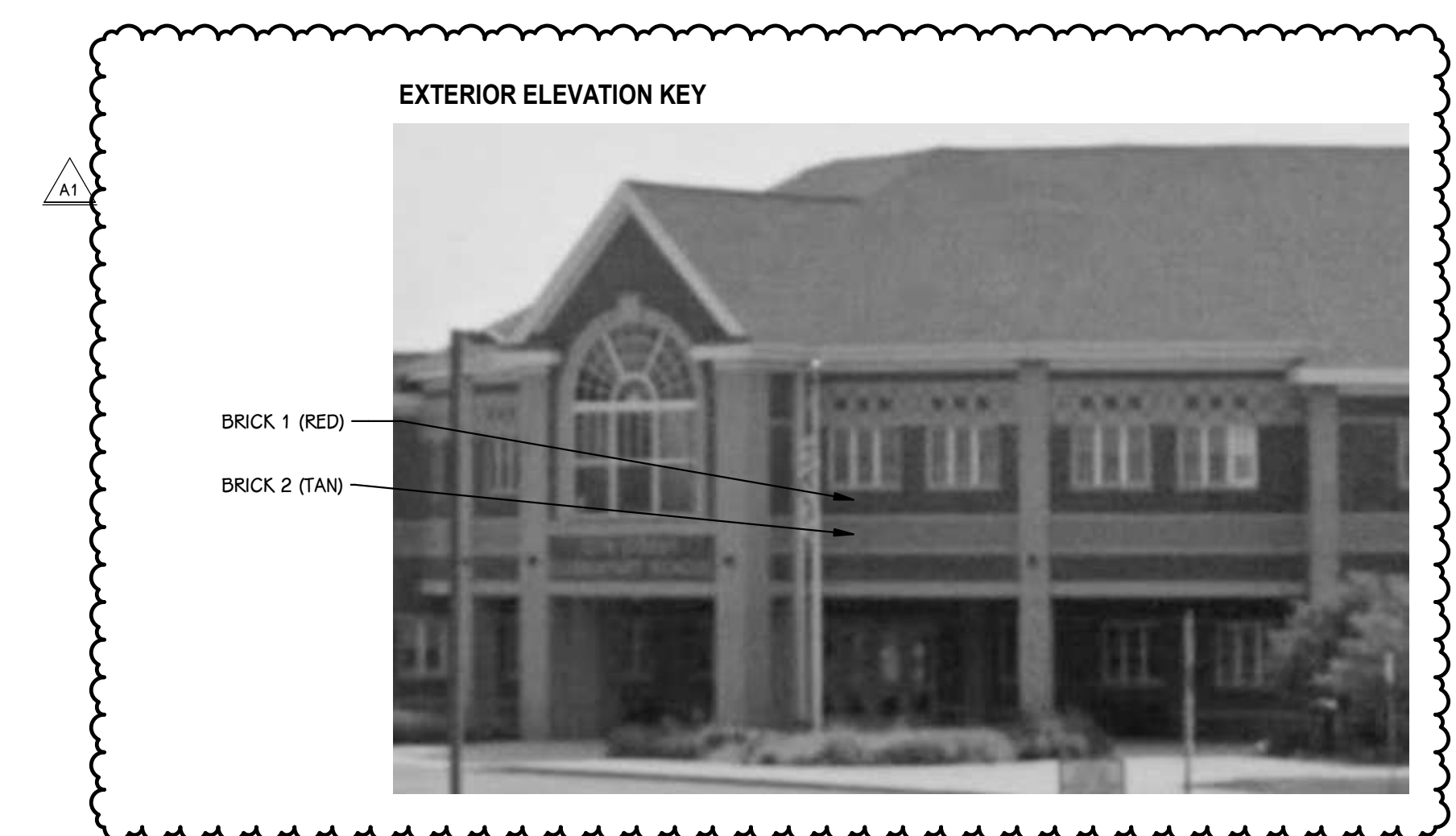

**Portage Public Schools – 12<sup>th</sup> St. Elementary Monument Sign  
Pre-Bid Meeting Agenda  
April 13<sup>th</sup>, 2026 – 2:00 PM**

**1. Introductions**

Steve Phelps	Portage Public Schools
Russ Gerbers	Portage Public Schools
Doug Milburn	Tower Pinkster
Ryan Ruitter	Owen-Ames-Kimball Co.
Aric Smith	Owen-Ames-Kimball Co.

**2. Safety**

- a. All roads and entrances must remain open.
- b. Contractors must follow proper safety procedures. Contractor safety manuals/books must be on-site.
- c. Contractors must provide their own first aid and fire protection equipment.
- d. Contractors are responsible for providing the necessary barricades for their work.
- e. Contractors must comply with the "Right to Know" law.
- f. Contractors are responsible for their own security.
- g. Contractors must comply with O-A-K's substance abuse policy.
- h. No Smoking on School Property.
- i. No pictures are to be taken during school hours.
- j. Contractors to stay out of occupied areas.
- k. No radios, boom boxes, I-pods, etc.... will be allowed on the construction site.

**3. Monthly Invoices**

- a. Monthly invoices must be submitted to O-A-K by the 20<sup>th</sup> of each month. Contractors must invoice on AIA forms G702 & G703.
- b. There will be a 10% retainage on invoices.
- c. If contractors' invoice for stored material not stored on-site, the invoice must be accompanied with an insurance certificate for that material.
- d. Performance and payment bonds, as well as certificates of insurance, must be on file prior to receiving progress payments.

**4. Insurance**

- a. Contractors must provide insurance certificates as per specifications. Insurance certificates must indicate the Owner, Architect, and C.M. as additional insured on a per project basis.
- b. Contractors must provide a 30 days notice of cancellation.
- c. Insurance must be on file 10 days after receipt of Notice of Pending Award.

**5. Testing, Permits, Inspections**

- a. Testing will be by the Owner.
- b. All necessary permits and inspections are the responsibility of each contractor.

**6. Site Constraints**

- a. Maintaining a clean site is mandatory.
- b. Construction traffic to use designated access roads only.
- c. Construction trailers and staging will be coordinated with OAK Superintendent – Aric Smith.

**7. Temporary Services**

- a. Temporary toilet facilities will be supplied by the Owner.
- b. Existing electrical services will be available for use. Contractors are to provide their own GFI protection.
- c. Existing water services will also be available for use.

**8. Layout**

- a. Each contractor is responsible for their own layout, the C.M. will assist.

**9. Bid Forms**

- a. Contractors are reminded to fill in all required items on the bid forms.
- b. If there are costs associated with an alternate, it must be listed on the bid form.
- c. This is **NOT** a prevailing wage job.
- d. Voluntary Alternates are encouraged - list accordingly on the bid form.
- e. Please note that there are Alternates. The write up will be in the Addendum.
- f. Mandatory alternates must be filled in. Blanks will be treated as zeros.
- g. Fill out all unit prices that pertain to your bid category.
- h. Familial Disclosure Statement must be signed and notarized.
- i. Bids shall be submitted for the complete project (all phases).

**10. Shop Drawings and Submittals:**

- a. All correspondence must be addressed to:  
Amelia Troyer  
Owen-Ames-Kimball Co.  
2700 Stadium Dr,  
Kalamazoo, MI 49008  
E-mail: [ameliat@oakmi.com](mailto:ameliat@oakmi.com)
- b. Contractors are required to send and receive submittals and shop drawings electronically. All Submittals will be returned electronically.
- c. Successful bidders maybe asked in the "Notice of Pending Award" to submit manpower and shop drawing schedule.

**11. Document Questions**

- a. All questions regarding the bid documents, schedule, or procedure must be addressed to  
Anastasia Wojcik  
269.251.6398  
Email: [anastasiaw@oakmi.com](mailto:anastasiaw@oakmi.com)
- b. Requests for Information must be submitted by April 15<sup>th</sup>, 12:00 PM. If an RFI is received after the cutoff period, it will not be answered prior to the bid date.

**12. Schedules / Key Topics:**

- a. This project will take place over the course of Portage Public Schools 2026 summer break.
- b. Expected start date: June 8<sup>th</sup>.

**13. Bid Details**

- a. Bids for the 12th Street Elementary – Monument Sign, and Portage Public Schools, will be received until 11:00am local time, Wednesday, April 22nd, 2026 at Owen-Ames-Kimball Co., 2700 Stadium Dr. Suite 2, Kalamazoo, MI 49008 or brought directly to the bid opening at Portage Public Schools Administration Building, 8107 Mustang Dr., Portage, MI 49002 at 2:00PM local time, Wednesday, April 22nd, 2026 and handed to an O-A-K employee
- c. If you would like to drop off bids to the offices of Owen-Ames-Kimball Co., they must be received by 12:00 PM April 22<sup>nd</sup>, 2026.
- d. FAXED, EMAILED OR UPLOADED TO BUILDING CONNECTED BIDS WILL NOT BE ACCEPTED
- e. Bid Bonds / Certified Checks

**14. General Notes**

- a. Each bidder must submit their bid per the plans, specifications, and construction management booklet. If your bid varies from these documents, you must submit the variance as a voluntary alternate with your base bid matching the bid documents.
- b. Each contractor must supply sufficient manpower.
- c. Storage will be allowed on site for each phase of construction only while in construction.
- d. The schedule does not change if alternates are accepted.



## 16. Comments and Questions